

Voltage : 12 Volt  
 Capacity : 50Ah  
 Dimensions : 277x106x222 mm (LxWxH)  
 Terminal : M6 insert (*bolt supplied*)  
 Container & lid : Flame Retardant ABS  
 Approximate weight : 17.3kg  
 Certificate(s) : CE, UL

- Typical Applications:**
- Telecommunication devices
  - Fire & burglar alarm systems
  - Audio and video broadcast systems
  - Building automation
  - Emergency lights
  - UPS systems
  - Remote measurement systems

**Capacity**  
 10 hour rate (5A) : 50Ah  
 5 hour rate (8.5A) : 42.5Ah  
 1 hour rate (33.1A) : 33.1Ah  
 15 minute rate (93.5A) : 23.4Ah

**Internal Resistance (fully charged) :** 8mOhm

**Capacity versus temperature**  
 40°C : 102%  
 25°C : 100%  
 0°C : 85%  
 -15°C : 65%

**Max. discharge current :** 500A (5 sec)

**Charge (constant voltage)**  
 Maximum charge current 15A  
 Float use: 13.6 - 13.8 Volt. -20mV/°C  
 Cyclic use: 14.4 - 14.7 Volt. -30mV/°C

The FA series is designed for use in 19" cabinets so that 4 batteries can be placed next to each other. Due to the front terminal the space between the batteries and the next shelf can be very small.

The manifold on each battery allows for the attachment of tubes that can be brought outside the cabinet to allow gasses that might develop in an over-charge condition to escape.

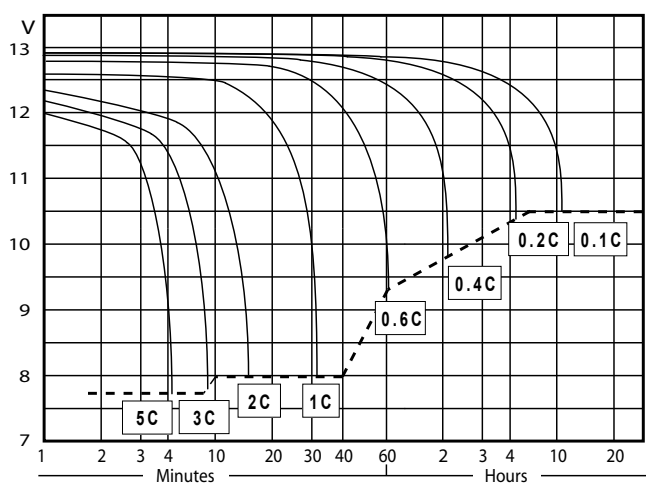
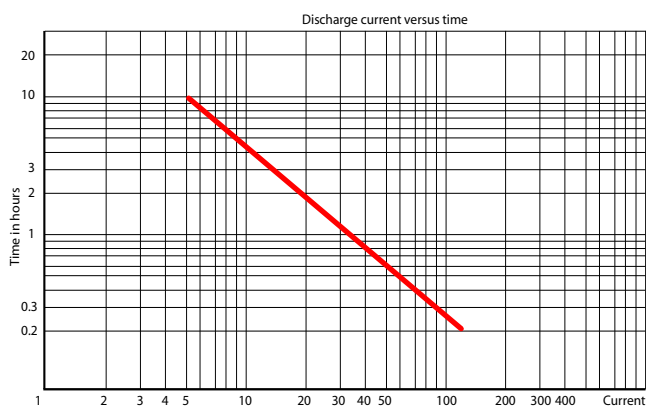

Discharge data watt/battery

	Discharge time	10 min	15 min	30 min	45 min	1h	2h	3h	5h	10h	24h
End Voltage	10.80	942	726	540	374	317	197	154	96.6	55.5	26.9
	10.50	996	816	551	385	325	199	155	97.2	55.9	27.1
	10.20	1050	888	557	395	335	202	158	99.0	56.9	27.5
	9.90	1104	930	565	416	350	209	161	100.8	58.0	28.1
	9.60	1176	978	579	434	364	215	166	101.4	58.3	28.3